

Probabilistic settlement analysis of rectangular footings

L'analyse de règlement de probabilitic de fondations rectangulaires

D.V. Griffiths
Colorado School of Mines, U.S.A.

G.A. Fenton
Dalhousie University, Canada

ABSTRACT

By modeling soil as a three-dimensional spatially random material, the reliability of shallow rectangular footings against serviceability limit state failure in the form of excessive settlement can be estimated. The methodology to be used is the 3-d random finite element method (RFEM) which combines finite element analysis with random field theory, where the mean, the standard deviation and the spatial correlation length of the modulus of the underlying soil can be controlled through the input data. The study starts by comparing settlements of rectangular footings against classical solutions for homogeneous deposits and then goes on to investigate the influence of footing aspect ratio on probabilistic settlements. Of particular interest is the relationship between the rectangular footing dimensions and the spatial correlation length of the underlying soil. The results of the studies are presented in probabilistic form, where for given statistics of soil input parameters, the probability of footing settlement exceeding a design criterion is assessed. Earlier studies on adjacent square footings indicated that distributions of settlements and differential settlements can be predicted using the geometric average of the underlying elastic soil modulus field. The current work on rectangular footings represents a further step towards developing a general probabilistic design framework for assessing settlements of shallow footings.

RÉSUMÉ

En modelant le sol comme un matériel spatialement fait au hasard à trois dimensions, la fiabilité de fondations rectangulaires peu profonds contre la limite d'aptitude à l'usage échec de l'état sous forme de règlement excessif peut être estimé. La méthodologie être utilisée est la méthode d'élément finie, faite au hasard et de 3 d (RFEM) qui combine l'analyse d'élément finie avec la théorie de champ faite au hasard, où les moyens, la déviation standard et la longueur de corrélation spatiale de la compressibilité (ou modulus) du dépôt fondamental peut être contrôlé par les données d'entrée. L'étude commence en comparant des règlements de fondations rectangulaires contre les solutions classiques pour les dépôts homogènes et va alors sur examiner l'influence de fondation de proportion d'aspect sur les règlements de probabilistic. D'intérêt particulier est la relation entre les dimensions de fondation rectangulaires et la longueur de corrélation spatiale du sol fondamental. Les résultats des études sont présentés dans la forme de probabilistic, où pour la statistique donnée de sol paramètres d'entrée, la probabilité de fondation de règlement dépassant un critère de conception est évalué. Plus tôt les études sur les fondations carrés adjacents indiqués que les distributions de règlements et de règlements différentiels peuvent être prédites utilisant la moyenne géométrique du champ de modulus de sol élastique fondamental. Une approche similaire sera utilisée dans le courant traite des fondations rectangulaires, comme une plus ample étape vers le développement d'un cadre de conception de probabilistic général pour évaluer de règlements de fondations peu profonds.

1 SETTLEMENT OF RECTANGULAR FOOTINGS

The settlement of structures founded on soil is a subject of considerable interest to practicing engineers since excessive settlements can lead to serviceability or even failure states in the structural elements above. Settlements are typically predicted using elastic theory where soil properties are generally expressed in terms of "compressibilities" (essentially the reciprocal of "moduli" values preferred by structural engineers). Due to the common problem of limited site investigation data, engineers typically use a rather conservative approach to settlement prediction based on experience, combined with pessimistic estimates of compressibility and loading conditions. In view of the variable nature of soil properties, a probabilistic approach to this problem has attractions because it enables the analyst to estimate the *probability* of settlement limits being exceeded (see e.g. Baecher and Ingra 1981, Righetti and Harrop-Williams 1981, Paice *et al* 1996). The approach also facilitates an understanding of the sensitivity of settlement prediction to various input parameters describing the soil variability.

In this paper, a probabilistic investigation of settlement of a single rectangular footing is described. Only the influence of uncertainties in the soil properties are considered here, with uncertainties that arise due to the model and loading conditions

left for future study. In addition, the soil is assumed to be isotropic, that is, the correlation structure is assumed to be the same in both the horizontal and the vertical directions. Although soils generally exhibit a stronger correlation structure in the horizontal direction, and the analysis tools used in this study can model anisotropy, this site specific refinement is not considered here. Our priority in this work is to establish the probabilistic behavior of the settlement of rectangular footings as a function of the various statistics of the underlying soil.

2. THE RANDOM FINITE ELEMENT METHOD (RFEM)

The method involves combining finite element analysis (e.g. Smith and Griffiths 2004) with random field theory (Vanmarcke 1984, Fenton and Vanmarcke 1990), where the latter is used to generate the material properties based on an underlying mean standard deviation and spatial correlation length. The analyses are then repeated using a Monte-Carlo approach until the output statistics of interest have stabilized. The authors have applied the method to a number of classical geotechnical problems (e.g. Griffiths and Fenton 2001,2004) and the interested reader is referred to those references for further details of the method. In this work the finite element simulations are simple elastic analyses, and the random field method is used to provide the Young's modulus values to be assigned to each element. The analyses involve a rigid, rough, rectangular footing at the

surface of a spatially random soil defined by the three properties relating to Young's modulus (E)

μ_E = mean, [1.0]
 σ_E = standard deviation [0.1, 0.5, 1.0]
 θ_{lnE} = correlation length [0.25, 0.5, 1.0]

The numbers in square parentheses refer to the range of values considered in the parametric studies. The Young's modulus distribution was assumed to be lognormal throughout this study.

Rigid rectangular footings with three different aspect ratios were considered with dimensions [1:1, $L=0.4$, $B=0.4$], [2:1, $L=0.8$, $B=0.4$] and [3:1, $L=1.2$, $B=0.4$]. The soil layer was finite with a depth of $H=1.0$. It should be noted that θ_{lnE} has units of length and must be given in the same system of units as that used to define the footing dimensions [B, L] and soil layer depth H . Poisson's ratio was fixed and set to $\nu=0.3$.

Since rectangular footings are being considered in this study, three-dimensional analyses are required and the present study makes use of 8-node hexahedral elements. A typical mesh used in this study is shown in Figure 1 and involves 60x60x20 (72,000) cubic elements and 234,423 degrees of freedom. This kind of mesh density is needed to model the random field to a reasonable resolution, but also leads to a stiffness matrix that is too big to store in the core of most conventional desktop computers (e.g. for the case shown in Figure 1, the stiffness matrix would require nearly a billion locations of storage even using the most efficient skyline storage strategy). Consequently a preconditioned conjugate gradient iterative solution strategy has been implemented in the current work that uses element-by-element products to entirely avoid the need to assemble large global matrices.

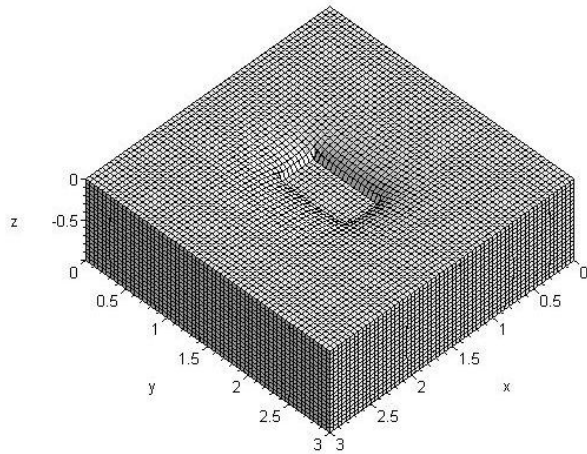

Figure 1, Mesh used for footing settlement study

The cubic elements each have a side length of 0.05, thus there are 8 elements under the width dimension of the footings and up to 24 under the length dimension.

In order to model a rigid rough footing, all the freedoms connected to the footing were "tied" and a single vertical force applied. In all cases a vertical force that would result in a net pressure on the footing equal to 1.0 was applied. Thus with a footing of dimensions [$B=0.4$, $L=0.8$], a force of 0.32 was applied and so on. The use of tied freedoms in this context ensures that all footing nodes settle vertically by the same amount with no rotation.

3. VALIDATION RUNS ASSUMING A HOMOGENEOUS SOIL

Before starting the Monte-Carlo simulations with random field generation, a series of validation runs were performed to estimate the footing settlement on a uniform elastic layer. The deformations shown in Figure 1 came from such an analysis in which $E=1.0$, $\nu=0.3$ with footing dimensions $L/B=2$, and depth ratio $H/B=2.5$ (where H is the depth of the soil layer). For a rigid rectangular foundation of these dimensions subjected to an average vertical pressure of unity, Milovic(1992) gives a settlement of 0.36 while the finite element analysis gave $\delta_{det}=0.29$. Selective reduced integration, non-conforming elements and even higher order (20-node) elements were attempted without significantly increasing the computed settlement. It is thought that the shear discontinuity at the edge of the "rigid" footing is responsible for the over stiff response and is the subject of further research. For the purposes of this investigation, the settlement obtained with a uniform stiffness set equal to the mean of the input distribution (δ_{det}) will be used as the baseline for comparison with results obtained later with variable properties. In any case, the probabilistic results can be easily scaled by δ_{det} so that the results are applicable even if the finite element results are too stiff by a multiplicative factor (see equation 3 for example).

4. SETTLEMENT ANALYSIS USING THE RANDOM FINITE ELEMENT METHOD (RFEM)

After the random field of properties has been mapped onto the mesh, a conventional elastic analysis is performed and the settlement of the rigid footing is recorded. The process is then repeated in the form of Monte-Carlo simulations with the same unit loading in each case. Each simulation involves the same random field parameters (mean, standard deviation and spatial correlation length) however the spatial location and values of the less stiff elements are different from one simulation to the next. For example, in one simulation the stiffer elements may happen to lie beneath the footing leading to a relatively small settlement value, whereas in another simulation the opposite may be the case. Each simulation leads to a different settlement value, and after a "sufficient" number of simulations have been performed, the statistics (mean and standard deviation) of the settlement start to stabilize.

The accuracy of these output values is a function of the input statistics of the Young's modulus field and the number of Monte-Carlo simulations performed. For example the greater the standard deviation of the Young's modulus field, the greater the number of simulation required to achieve a given level of accuracy. If n_{sim} Monte-Carlo simulations are performed, the estimated (sample) mean settlement will have a standard error (\pm one standard deviation) equal to the sample standard deviation times $1/\sqrt{n_{sim}}$. Many of the results presented in this paper used $n_{sim}=1000$, hence the estimated standard error will be $1/\sqrt{1000}=0.032$ or about 3% of the sample standard deviation of the settlement. Similarly, the estimated variance will have a standard error equal to the sample variance times $\sqrt{2/(n_{sim}-1)}$ or $\sqrt{2/999}$ which is about 4% of the settlement sample variance.

5. PROBABILISTIC INTERPRETATION OF RFEM RESULTS

The first plot that should be considered is a histogram of the computed settlements for all the Monte-Carlo realisations. If this plot is normalised such that the area enclosed beneath it is unity, the interpretation of probabilities is particularly convenient. For example, Figure 2 shows the histogram

obtained for a 3:1 rectangular footing following 1000 realisations with the following input parameters relating to the statistics of Young's modulus:

$$\mu_E = 1.0, \quad \sigma_E = 0.5, \quad \theta_{\ln E} = 0.25$$

These input parameters correspond to a Coefficient of Variation $V_E = 0.5$ and a correlation length given in dimensionless form in relation to the footing width as $\theta_{\ln E}/B = 0.625$

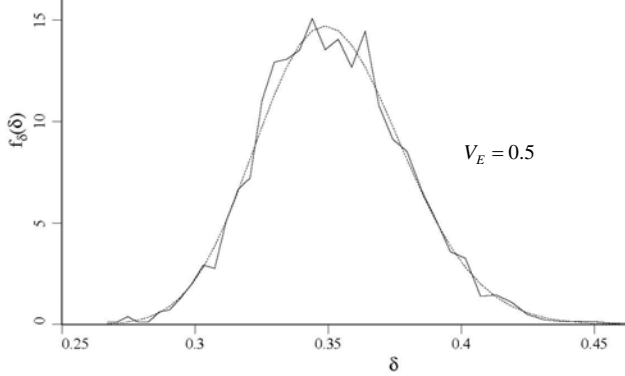

Figure 2. Histogram of RFEM settlement for a 3:1 rectangular footing. Lognormal fit to data is also shown

In the figure, the variable δ is the rigid footing settlement. The smooth line in Figure 2 represents a lognormal fit to the RFEM results from which probabilistic interpretations can be made. For example, the probability of a particular design settlement value being exceeded is given by the area under the curve to the right of that value. In order to obtain these probability estimates it is best to perform the calculation in the normal space corresponding to the log of settlement.

The probability of the settlement exceeding δ_{design} , which will be written as $p(\delta > \delta_{design})$, is given by:

$$p(\delta > \delta_{design}) = 1 - \Phi\left(\frac{\ln \delta_{design} - m_{\ln \delta}}{s_{\ln \delta}}\right) \quad (1)$$

where Φ is the cumulative normal function.

As an example, let $\delta_{design} = 0.4$. The lognormal fit shown in Figure 2 curve has the parameters,

$$m_{\ln \delta} = -1.047 \quad s_{\ln \delta} = 0.077$$

hence,

$$\begin{aligned} p(\delta > 0.4) &= 1 - \Phi\left(\frac{\ln 0.4 + 1.047}{0.077}\right) \\ &= 1 - \Phi(1.698) \\ &= 1 - 0.955 \\ &= 0.045 \end{aligned} \quad (2)$$

indicating a probability of about 4.5% that the settlement will exceed 0.4.

6. PARAMETRIC STUDIES

In this section, some of the results are presented relating to the different footing aspect ratios and input statistics indicated in Section 2. Figure 3 shows the influence of the correlation length $\theta_{\ln E}$ on the mean settlement for a square footing and a rectangular footing with an aspect ratio of 3:1. The settlements are non-dimensionalised by dividing the mean settlement by the deterministic settlement δ_{det} that would be obtained in a homogeneous soil with the stiffness everywhere equal to μ_E . The correlation length is non-dimensionalised by dividing it by the width of the footing B . It is shown that in all cases, the randomly distributed Young's modulus causes the mean settlement to be greater than the deterministic value.

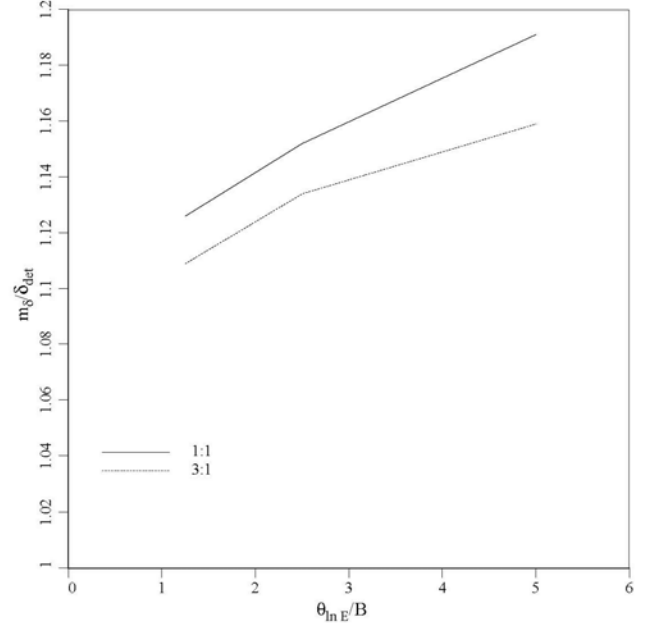

Figure 3. Normalised results for square and 3:1 rectangular footings for $CV_E = 0.5$. Mean settlement vs. correlation length

As $\theta_{\ln E}/B$ is increased, the mean settlement also increases, however the rate of increase decreases. The increased settlement due to the stochastic foundation is more pronounced for the square footing than for the rectangular one.

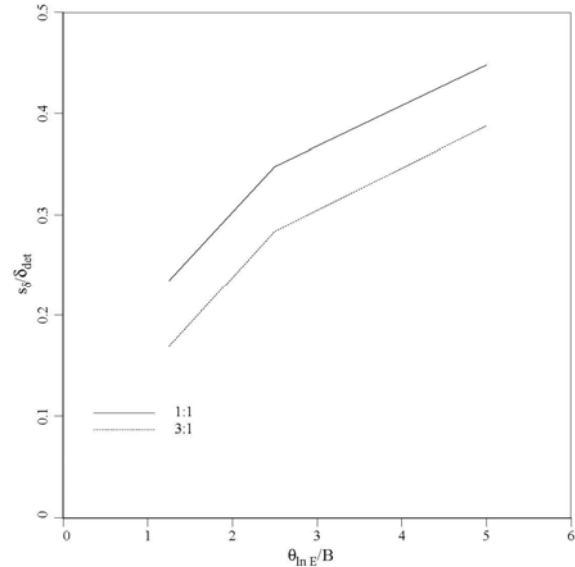

Figure 4. Normalised results for square and 3:1 rectangular footings for $CV_E = 0.5$. Standard deviation of settlement vs. correlation length.

A similar plot is shown in Figure 4 in which the standard deviation of the settlement is shown as a function of spatial correlation length. It is seen that in this case the standard deviation also increases with the spatial correlation and is higher for the square footing. Figures 3 and 4 together indicate that within the range of $\theta_{\ln E}$ values considered, the square footing will always lead to a higher probability that the settlement will exceed a design value.

In probabilistic analyses such as those presented in this paper, it is often instructive to consider the results that would be obtained with limiting values of spatial correlation length changing from very large to very small values. As $\theta_{\ln E} \rightarrow \infty$, each Monte-Carlo simulation involves an essentially uniform soil with stiffness E varying from one realisation to the next. At each realisation, the settlement is inversely proportional to the Young's modulus value and is given by

$$\delta = \frac{\delta_{\text{det}} \mu_E}{E} \quad (3)$$

where δ_{det} is the settlement that would be obtained deterministically on a homogeneous soil with a stiffness given by μ_E . Taking logs of both sides of equation 3 leads to

$$\ln \delta = \ln \delta_{\text{det}} + \ln \mu_E - \ln E \quad (4)$$

Since $\ln \delta_{\text{det}}$ and $\ln \mu_E$ are constant, this shows that if $\ln E$ is normally distributed (E is lognormal), then $\ln \delta$ will also be normal with parameters

$$\begin{aligned} \mu_{\ln \delta} &= \ln(\delta_{\text{det}}) + \ln(\mu_E) - \mu_{\ln E} = \ln(\delta_{\text{det}}) + \frac{1}{2} \sigma_{\ln E}^2 \\ \sigma_{\ln \delta} &= \sigma_{\ln E} \end{aligned} \quad (5)$$

At the other extreme, as $\theta_{\ln E} \rightarrow 0$, the influence of local averaging is to remove all variance of Young's modulus, leading to essentially identical analyses at each realisation with the soil stiffness homogeneous and equal to the median of the input distribution.

Thus if μ_E and σ_E are the input parameters of the lognormal distribution, then with $\theta_{\ln E} \rightarrow 0$, the Young's modulus assigned to each element tends to the median, thus

$$\mu_{\delta} = \frac{\delta_{\text{det}} \mu_E}{\text{median of } E} = \delta_{\text{det}} \sqrt{1 + V_E^2}$$

where the median is given by $\exp(\mu_{\ln E})$.

An important observation from these studies is that taking $\theta_{\ln E}$ large is conservative. The assumption that E is lognormally distributed and spatially constant leads to the largest variability across realisations in footing settlement. This observation is consistent with the higher mean and standard deviation observed in Figures 3 and 4 for the smaller (square) footing in which the relative size of $\theta_{\ln E}$ was larger than for the elongated 3:1 footing. Thus, traditional approaches to randomness in footing settlement using a single random variable to characterise E are conservative and will lead to overestimated probabilities of design "failure".

7. CONCLUDING REMARKS

At some sites, unusual ground conditions or foundation geometry will benefit from an entirely new set of analyses using the RFEM. For qualitative and "quick" estimates of probabilistic settlement, the authors have developing some empirical approaches using curve fits to comprehensive suites of RFEM results. These approaches enable engineers to estimate the probabilistic performance of sites without having to resort to the relatively time-consuming and computationally

intensive RFEM approach. The authors are also currently preparing the software used in these analyses (called `rset13d`) for dissemination in the public domain. In the meantime, interested readers should refer to Fenton and Griffiths (2002, 2004) for the design methodology. In brief, the empirical approaches are based on using a geometric average of the soil modulus taken over a strategic 3-d zone beneath the footing.

Many more parametric studies have been performed by the authors than have been presented and discussed in this paper. A companion paper is also being prepared that will include a more comprehensive review of these results.

8. REFERENCES

- G.B. Baecher and T.S. Ingra (1981), Stochastic FEM in settlement predictions, *Geotech Eng Div, ASCE*, 107(4), pp 449-463
- D.V. Griffiths and G.A. Fenton (2001), Bearing capacity of spatially random soil: the undrained clay Prandtl problem revisited. *Geotechnique* 51(4), pp. 351-359
- D.V. Griffiths, D.V. and G.A. Fenton (2004) Probabilistic slope stability analysis by finite elements. *ASCE J Geotech Geoenv Eng*, 130(5), pp.507-518
- G.A. Fenton and E.H. Vanmarcke (1990), Simulation of random fields via local average subdivision, *J Eng Mech, ASCE*, 116(8), pp. 1733-1749
- G. A. Fenton and D. V. Griffiths (2002) Probabilistic foundation settlement on spatially random soil, *ASCE J Geotech Geoenv Eng*, 128(5), pp. 381-390
- G.A. Fenton and D.V.Griffiths (2004), Three-dimensional probabilistic foundation settlement. To appear *ASCE J Geotech Geoenv Eng*.
- G. M. Paice, D. V. Griffiths and G. A. Fenton (1996), Finite element modeling of settlements on spatially random soil, *Geotech Eng Div, ASCE*, 122(9), pp. 777-779
- G. Righetti and K. Harrop-Williams (1988), Finite element analysis of random soil media year, *Geotech Eng Div, ASCE*, 114(1), pp 59-75
- I. M. Smith and D. V. Griffiths (2004), *Programming the Finite Element Method*, 4th ed, John Wiley & Sons, Chichester, UK
- E.H. Vanmarcke (1984) *Random fields: Analysis and synthesis*, The MIT Press, Cambridge, Mass.

9. ACKNOWLEDGEMENT

The authors acknowledge the support of NSF grant number CMS-0408150.