

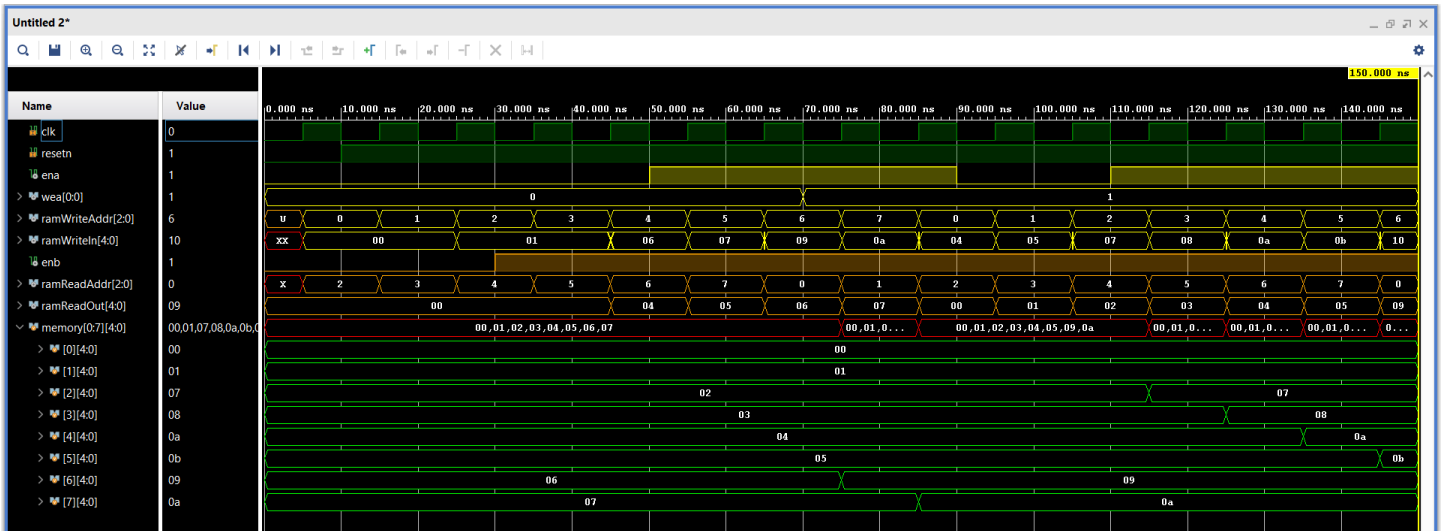

EENG 498 – Embedded Systems II

Simple Dual Port Ram

simpleDualPortRamWithCounters

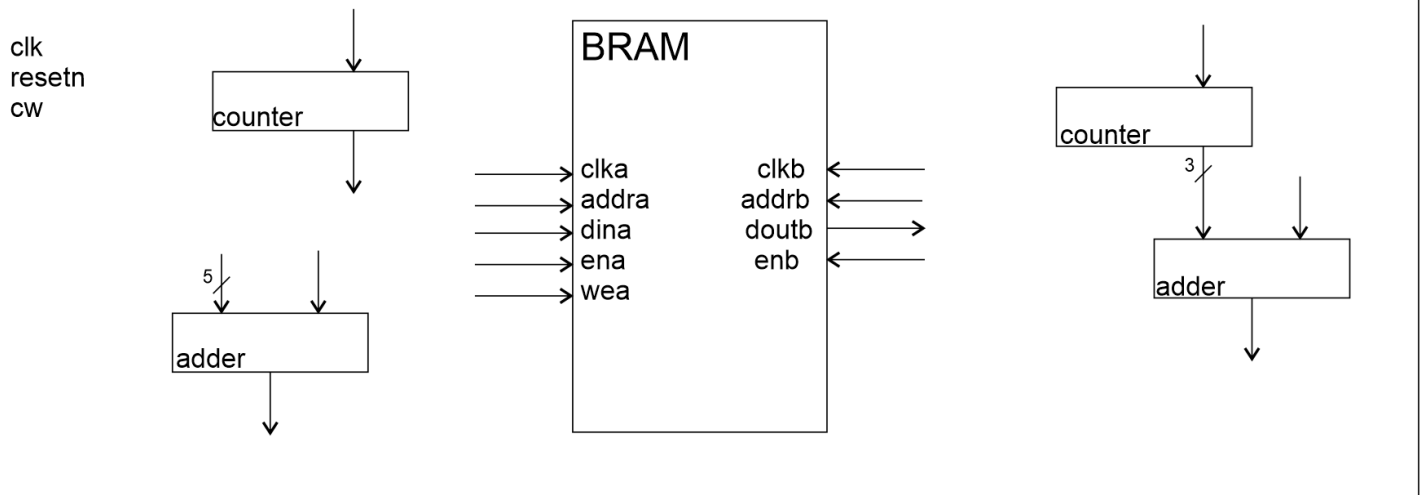



```
entity simpleDualPortRamWithCounters is
  PORT ( clk : in  STD_LOGIC;
         resetn : in  STD_LOGIC;
         cw: in STD_LOGIC_VECTOR(2 downto 0));
end simpleDualPortRamWithCounters;

architecture structure of simpleDualPortRamWithCounters is

  CONSTANT DATA_WORD_WIDTH : NATURAL := 5;

begin
  ena <= cw(2);    wea <= cw(1 downto 1);    enb <= cw(0);
  ramWriteAddr <= writeCounterQ(2 downto 0);

  bram_inst: blk_mem_gen_0
    PORT MAP (
      clka => clk,
      ena => ena,
      wea => wea,
      addra => ramWriteAddr,
      dina => ramWriteIn,
      clkb => clk,
      enb => enb,
      addrb => ramReadAddr,
      doutb => ramReadOut);

  adderWrite_inst: genericAdder
    GENERIC MAP (DATA_WORD_WIDTH)
    PORT MAP(  a => ramReadOut, b => writeCounterQ(5 downto 1), sum => ramWriteIn);

  writeCounter_inst: genericCounter
    GENERIC MAP (6)
    PORT MAP ( clk => clk, resetn => resetn, c => "10", d => (others => '0'),
              q => writeCounterQ);

  adderRead_inst: genericAdder
    GENERIC MAP (3)
    PORT MAP(  a => readCounterQ, b => "010", sum => ramReadAddr);

  readCounter_inst: genericCounter
    GENERIC MAP (3)
    PORT MAP ( clk => clk, resetn => resetn, c => "10", d => (others => '0'),
              q => readCounterQ);

end structure;
```